

8 | 7 | 6 | 5 | 4 | 3 | 2 | 1

D

D

C

C

B

B

A

A

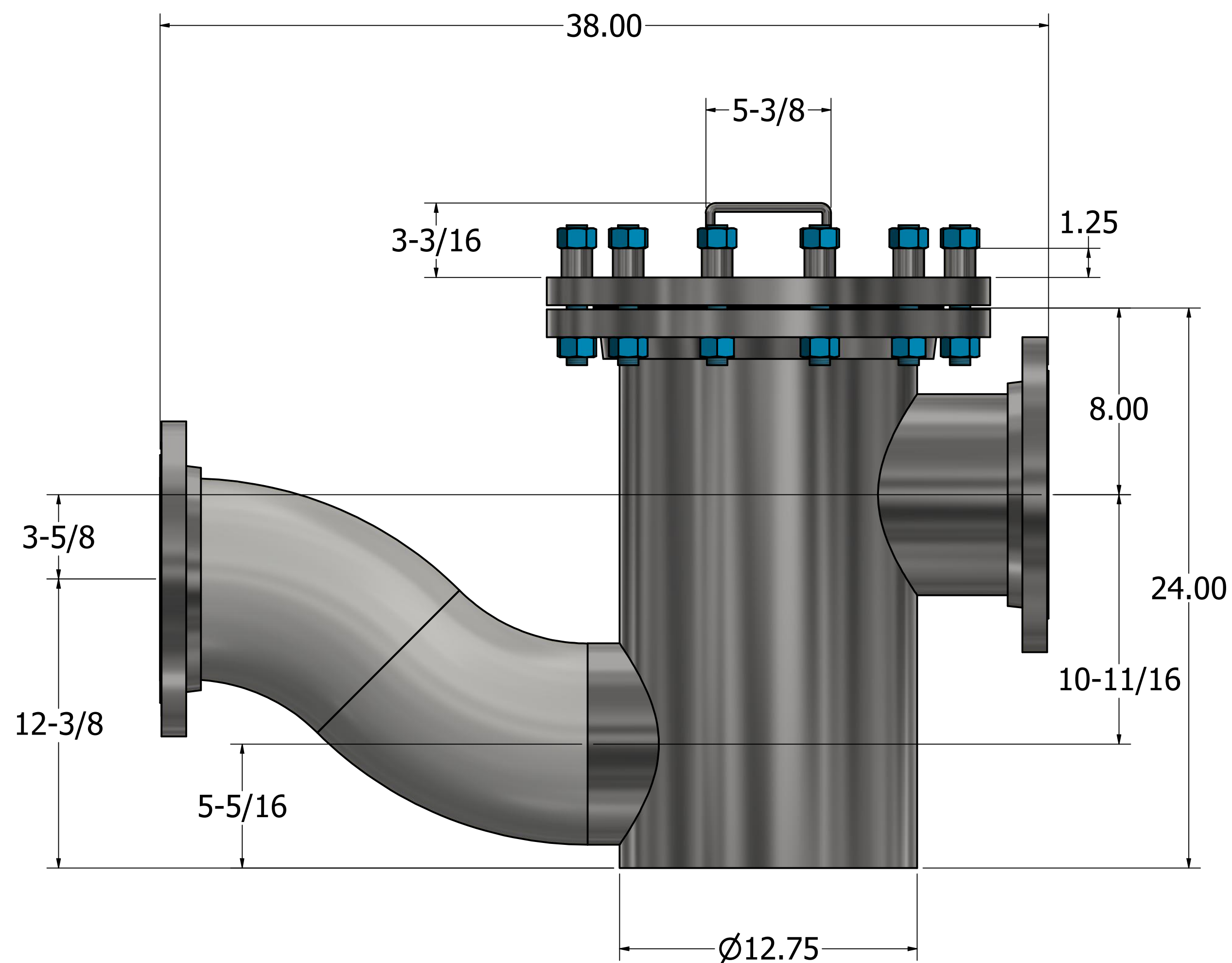
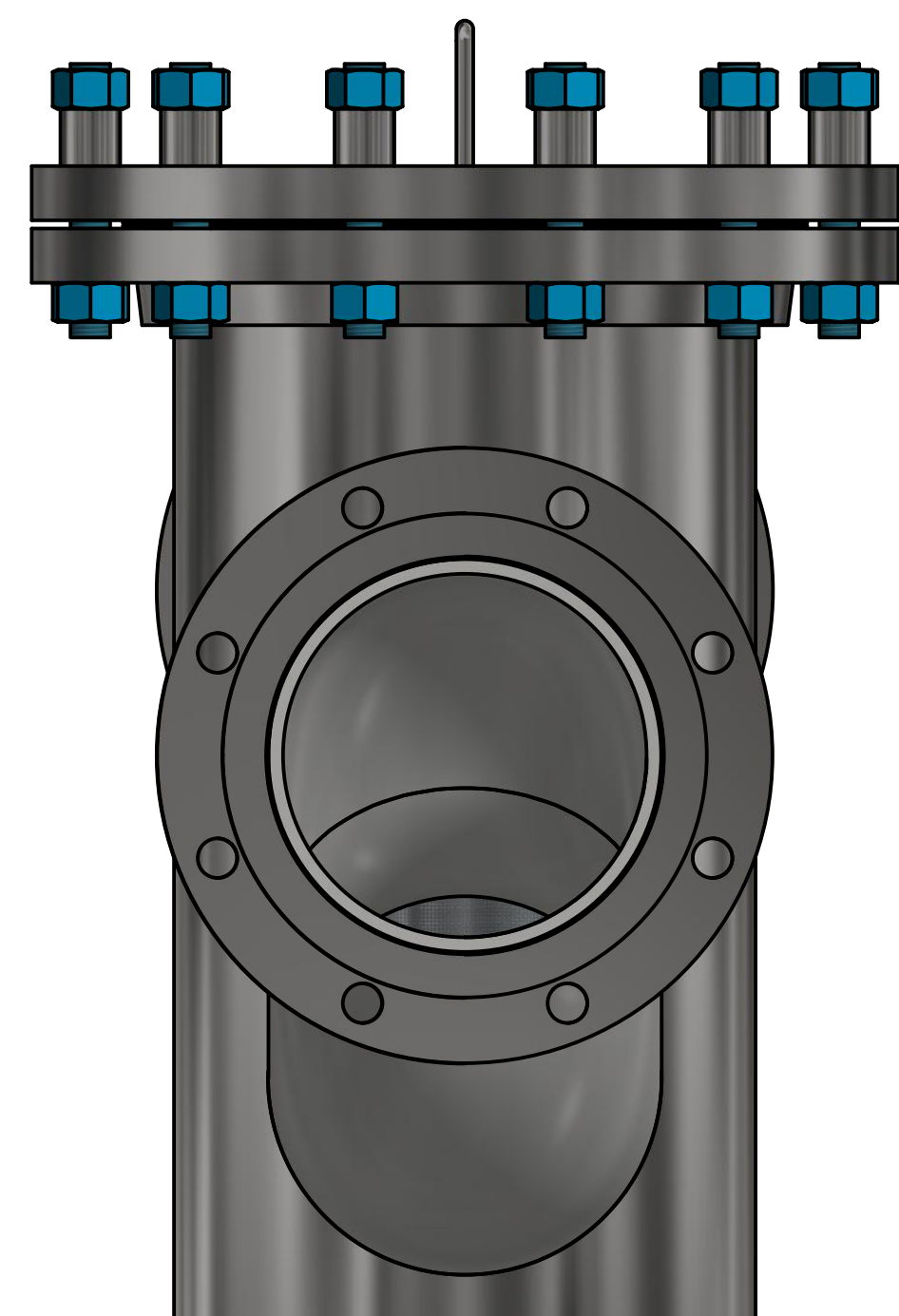

12" 150# SORF

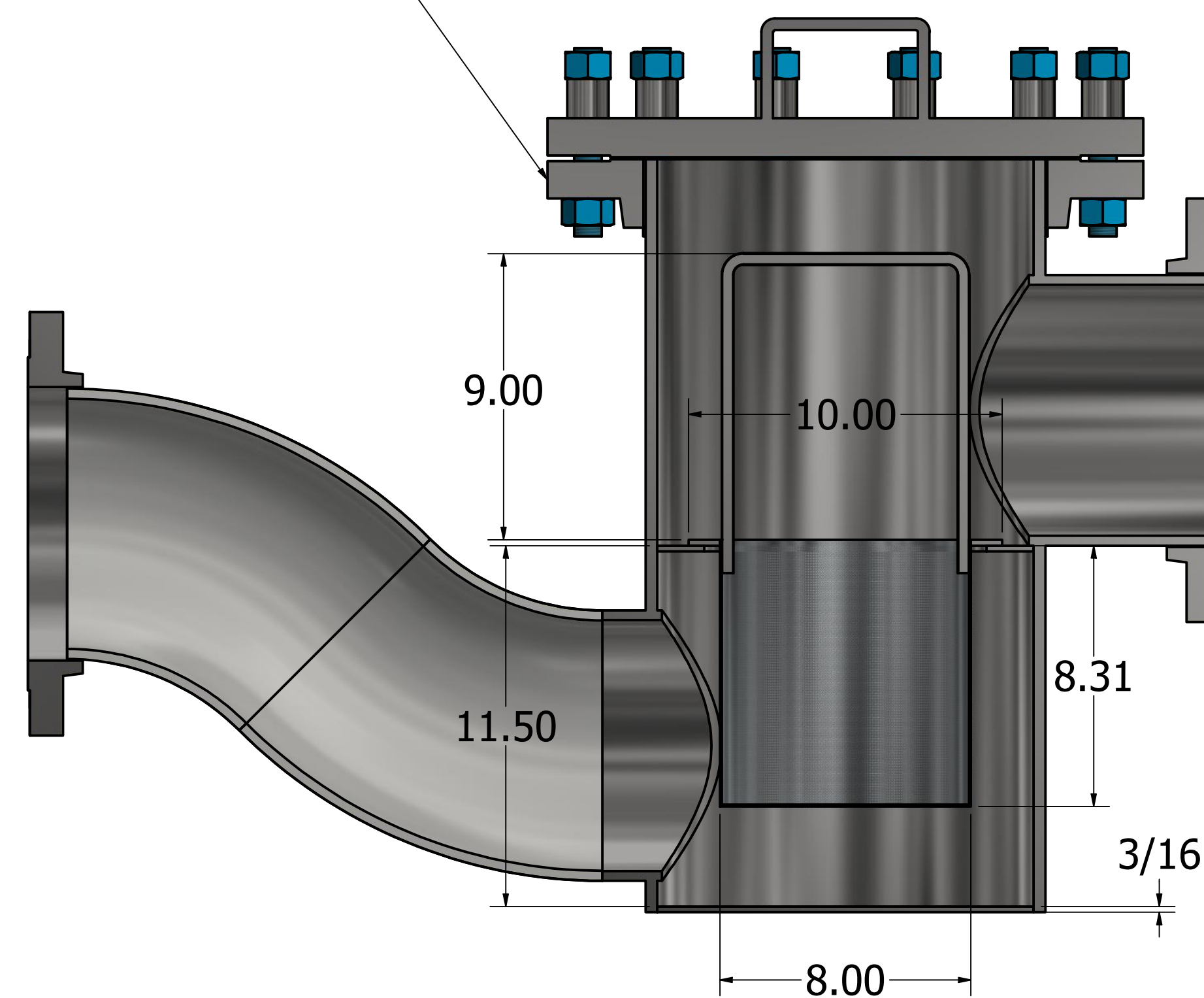

ALL DIMENSIONS ARE INCHES  
 TOLERANCES ARE +/- 1/16"  
 FLANGES ARE CLASS 150#  
 SCHEDULE IS 10 WHERE POSSIBLE

BASKET IS COMPOSED OF:  
 5 MESH 0.156" (5/32" SCREEN) - JDK

ALL MATERIAL IS 316SS

STUDS ARE B7 A193 PLUS NUTS TEFLON COATED

8" 150# SORF

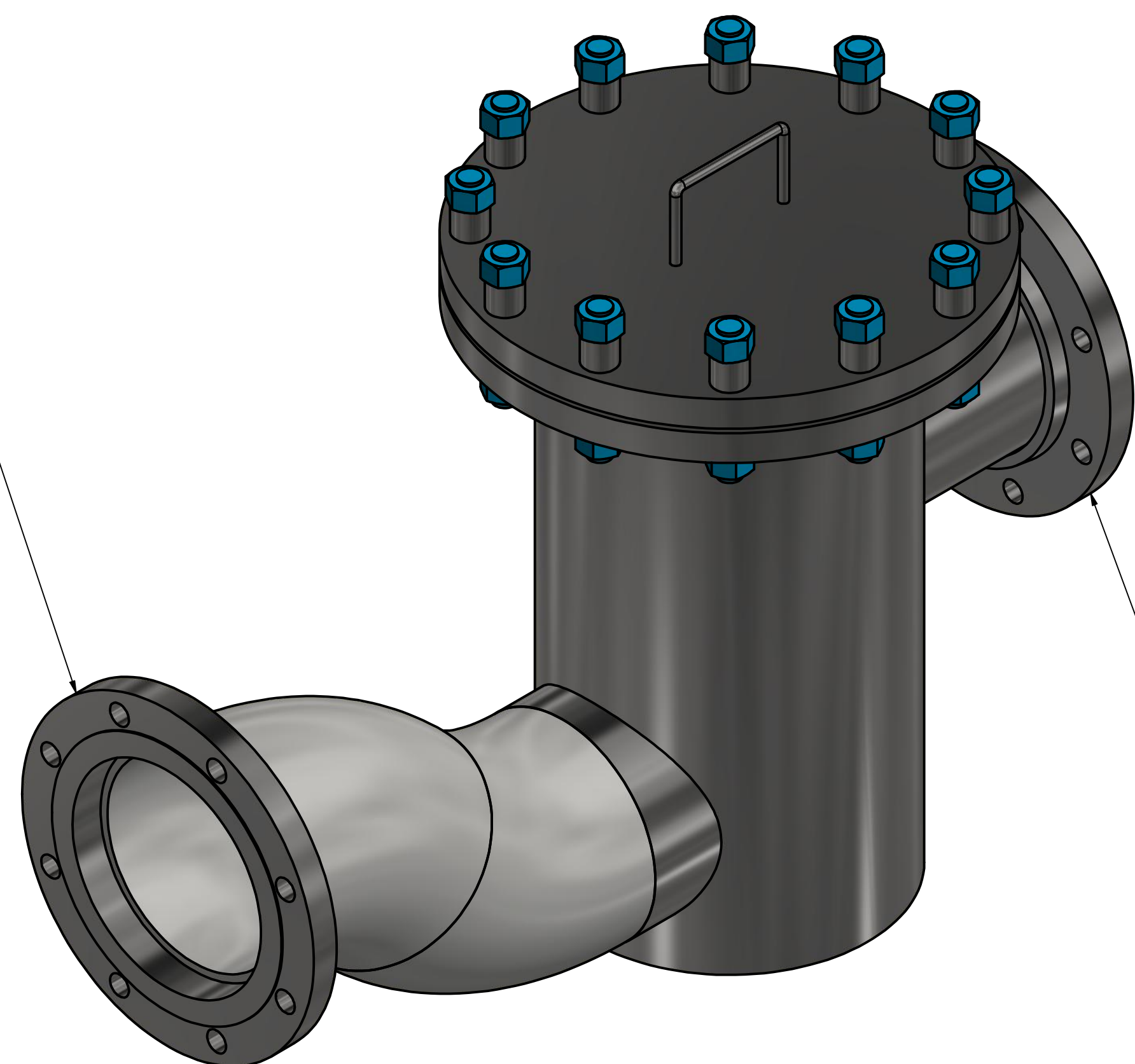

8" 150# SORF

DRAWN A SUBERO	5/5/2021	FLUID FILTRATION MFG CORP	
CHECKED		TITLE	
QA		CORN SYRUP STRAINER	
MFG		316SS JOB 3821	
APPROVED		SIZE D	REV 1
		SCALE 0.25	DWG NO MOTION.3821.CSS.1
		SHEET 1 OF 1	

8 | 7 | 6 | 5 | 4 | 3 | 2 | 1