

ALL DIMENSIONS ARE INCHES

CONSTRUCTION AS PER ASME SECTION VIII
 MAX WORKING PRESSURE: 150 PSI
 HYDROTEST PRESSURE 205 PSI
 MAX TEMP: 250°F
 MIN TEMP: -20°F

CERTIFIED DRAWING CARBON STEEL

CUSTOMER:

CUSTOMER PURCHASE ORDER:

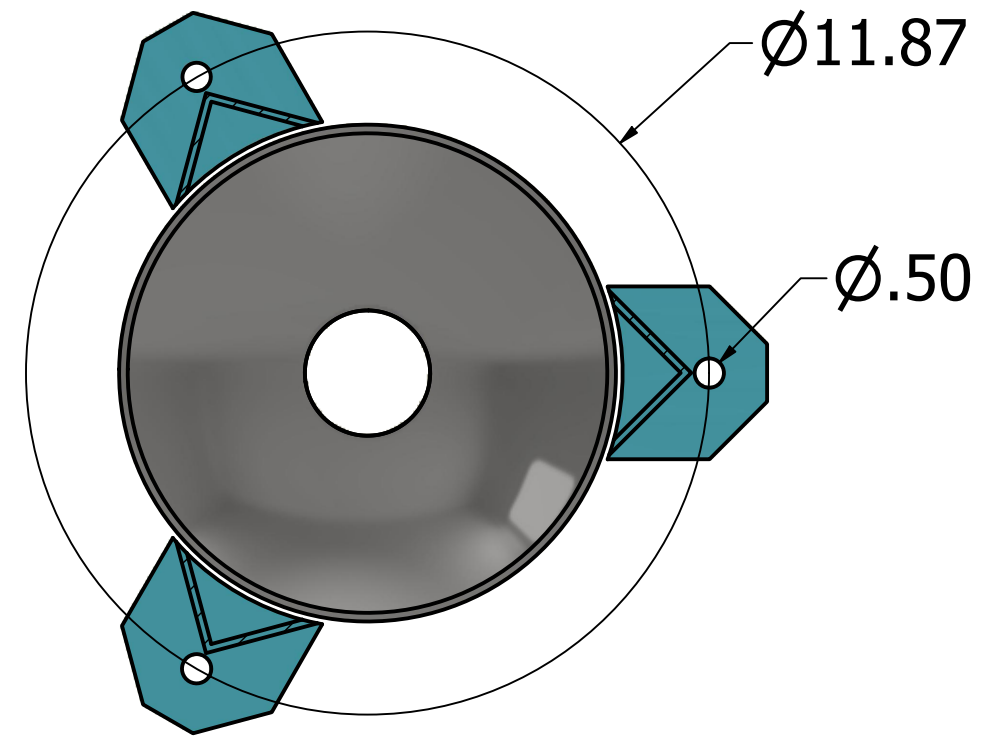

SECTION A-A
SCALE 0.3

STAND OFF HEIGHT
REQUIRED FOR BASKET REMOVAL
34.00

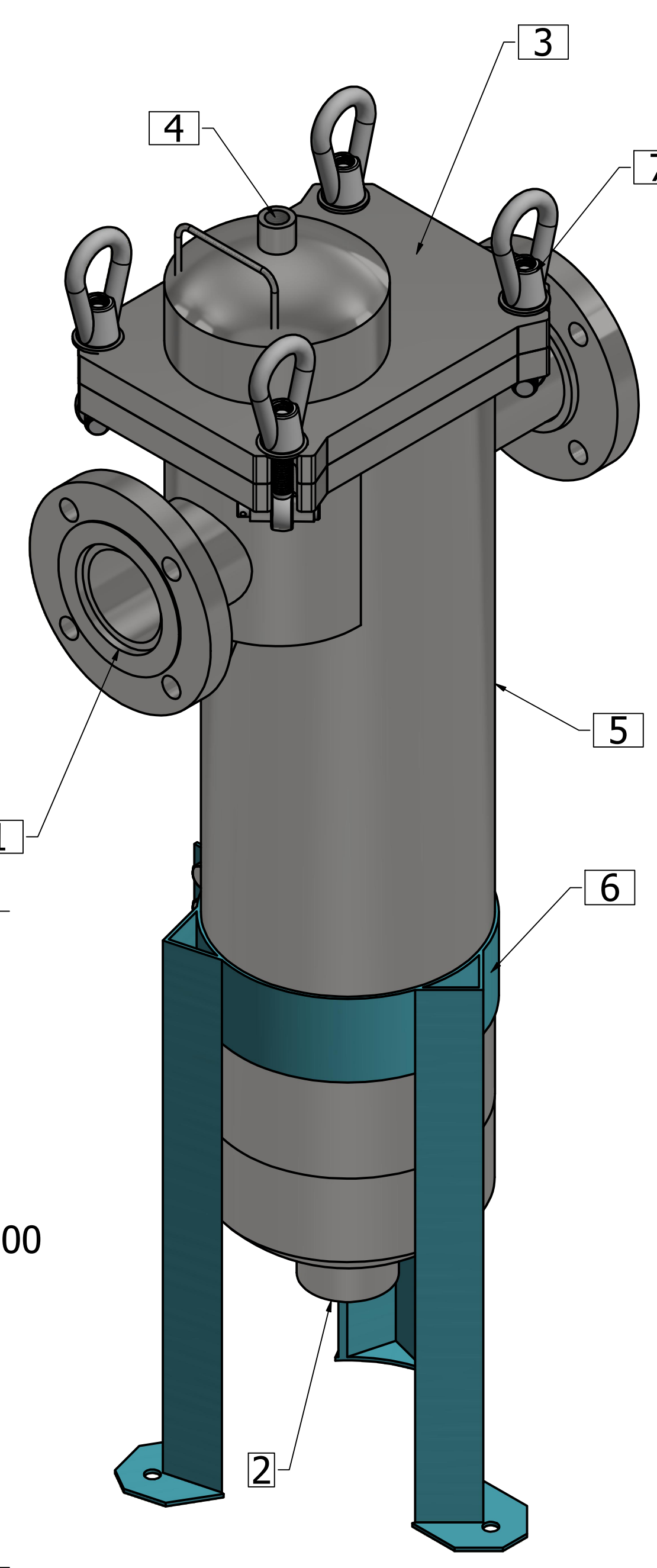
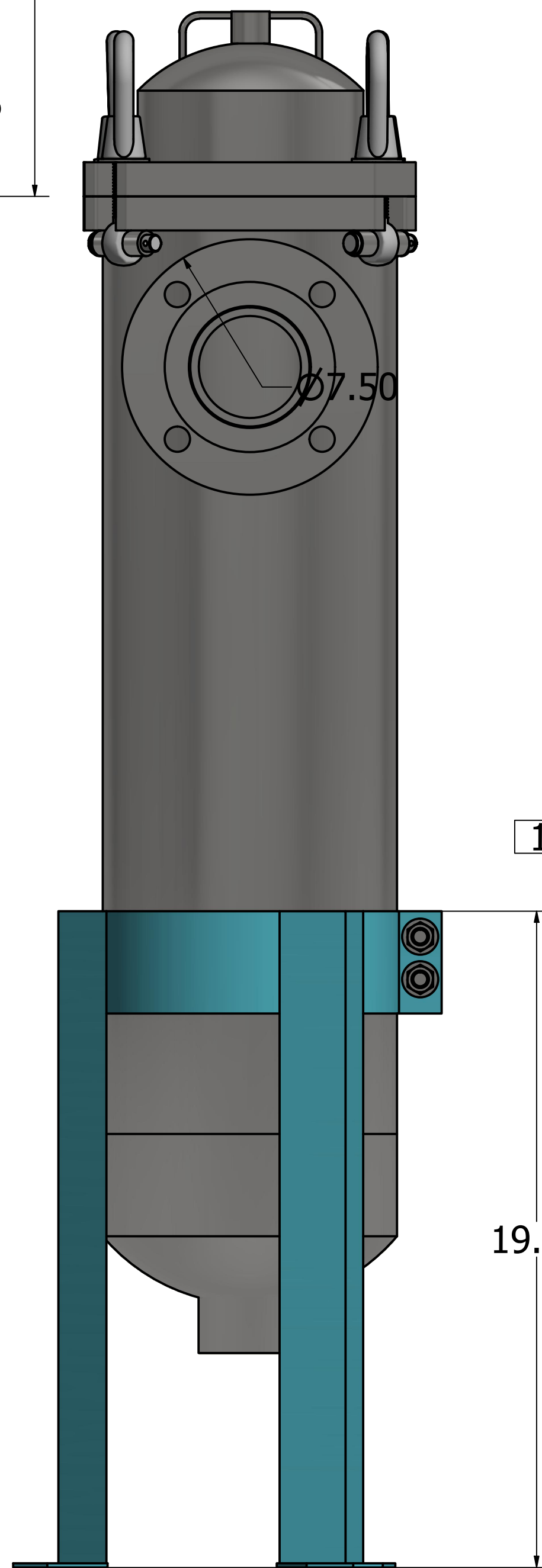
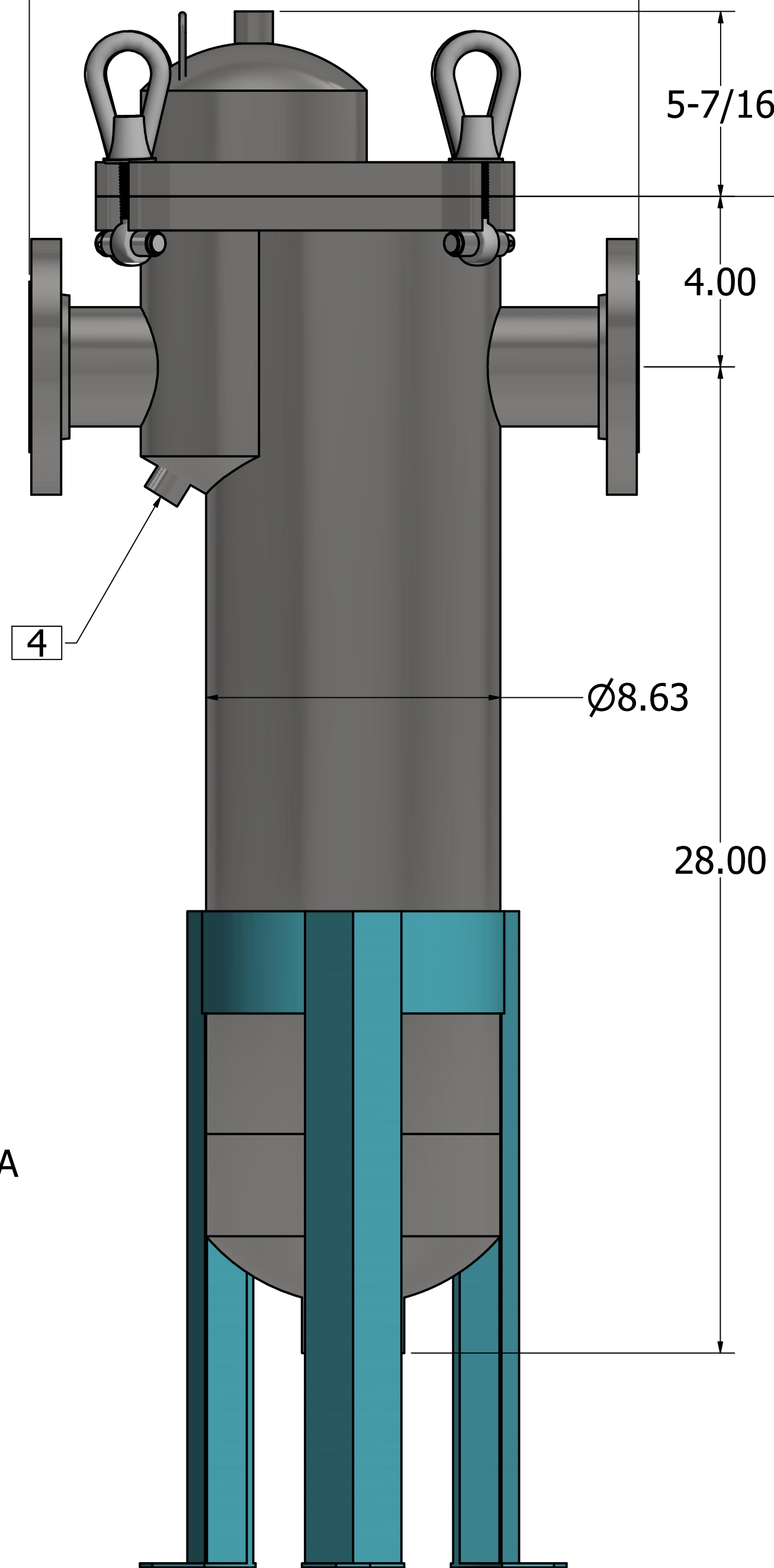
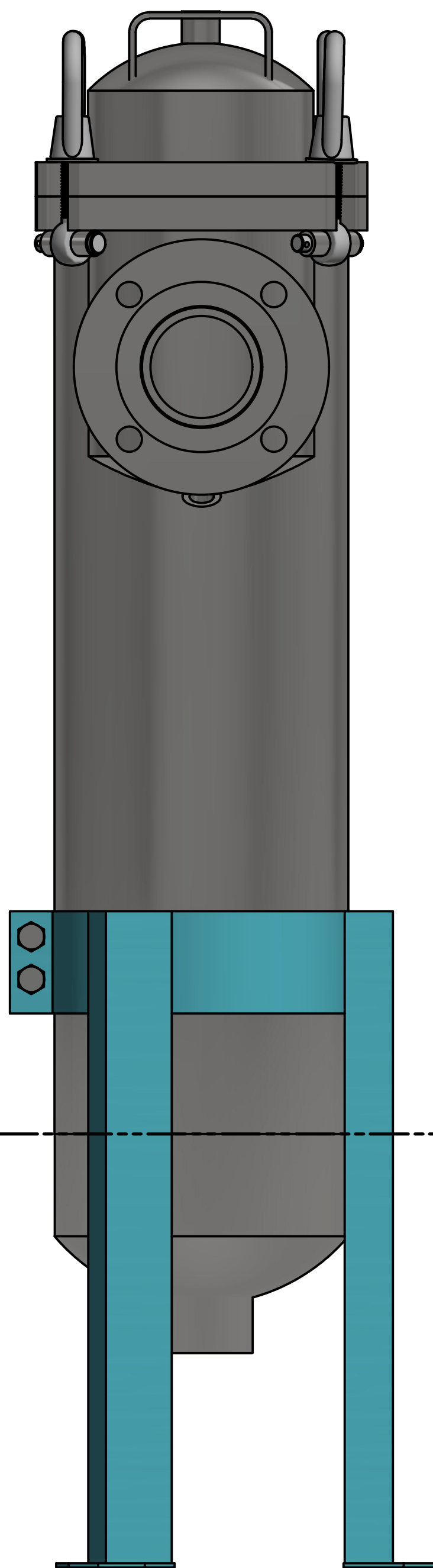

TABLE				
ITEM	QTY	PART NUMBER	DESCRIPTION	MATERIAL
1	2	SORF-3.0	Inlet/Outlet Flanges 3"-150# SORF	ASTM A-182 Gr F1
2	1	FF.PR.006	Drain Connection 2" NPTF CLASS 3000	ASTM A-182
3	2	FF.PR.001	Top Cover; Includes upper flange/cap with integral handle	ASTM A-240
4	2	FF.PR.004	Vent connection and Inlet Drain Connection	ASTM A-182
5	1	FF.PR.002.1	Central Body 8-5/8" OD	ASTM A-312
6	1	FF.PR.003	Fabricated 1-1/12 Angle with band and locking bolt	ASTM A-240
7	4	SA-194-1 SA-193-B7	Eyebolt/Eyebolt Assembly Clevis Pin SS Clotter Pin	ASTM A-193-B7/A-194-1 Cadmium Coated
NOT SHOWN	1	FF.PR.005	Lid Gasket	EPDM
NOT SHOWN	1	FF.PR.007	RESTRAINER BASKET	316SS 9/64' PERF

DRAWN J PERINO	2/8/2021	FLUID FILTRATION MFG CORP		
CHECKED A SUBERO	02/08/2021	TITLE		
QA		FILTER ASSEMBLY		
MFG A BORZI		FF.PR.3.0.150.2.316SS		
APPROVED		SIZE D	DWG NO FF.PR.3.0.150.2.SS	REV 0
		SCALE 0.3	SHEET 1 OF 1	