

8 | 7 | 6 | 5 | 4 | 3 | 2 | 1

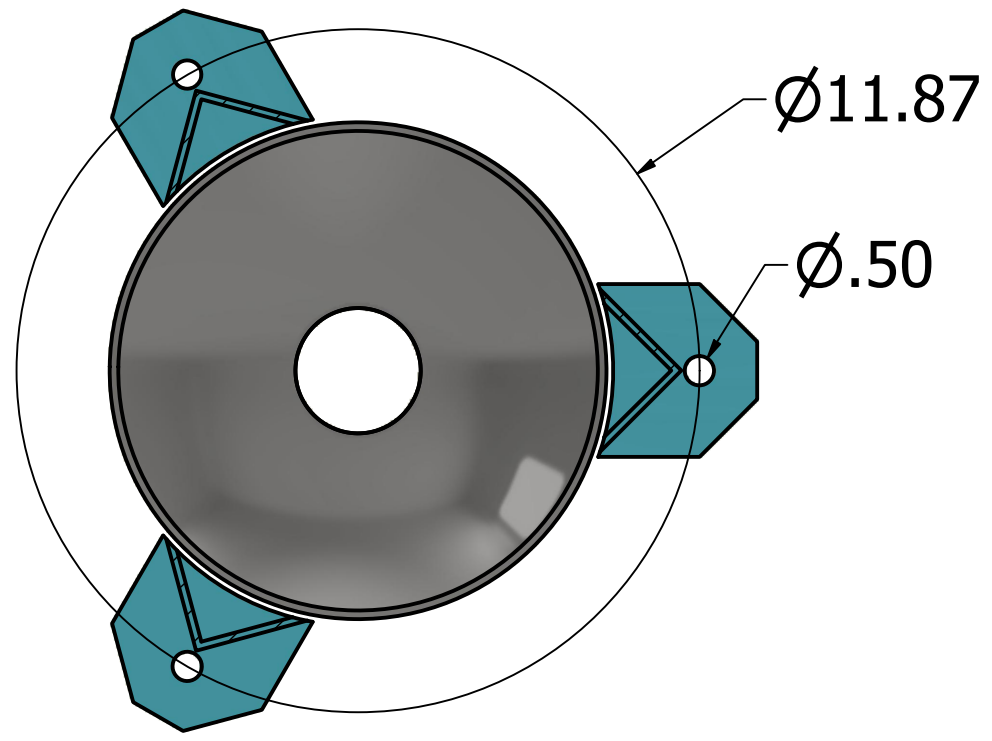

STAND OFF HEIGHT  
REQUIRED FOR BASKET REMOVAL

34.00

ALL DIMENSIONS ARE INCHES

CONSTRUCTION AS PER ASME SECTION VIII  
 MAX WORKING PRESSURE: 150 PSI  
 HYDROTEST PRESSURE 205 PSI  
 MAX TEMP: 250°F  
 MIN TEMP: -20°F

CERTIFIED DRAWING

CUSTOMER:

CUSTOMER PURCHASE ORDER:

TABLE				
ITEM	QTY	PART NUMBER	DESCRIPTION	MATERIAL
1	2	NPTF-2.0	Inlet/Outlet 2" NPTF CLASS 3000	ASTM A-105
2	1	FF.PR.006	DRAIN CONNECTION 2" NPTF CLASS 3000	ASTM A-105
3	2	FF.PR.001	Top Cover; Includes upper flange/cap with integral handle	ASTM A-36
4	2	FF.PR.004	Vent connection and Inlet Drain Connection 1/2" NPTF CLASS 3000	ASTM A-105
5	1	FF.PR.002.1	Central Body 8-5/8" OD	ASTM-A53
6	1	FF.PR.003	Fabricated 1-1/12 Angle with band and locking bolt	ASTM A-36
7	4	SA-194-1 SA-193-B7	EYE BOLT/EYE NUT ASSEMBLY CELVIS PIN SS CLOTTER PIN	ASTM A-193-B7/ A-194-1 Cadmium Coated
NOT SHOWN	1	FF.PR.005	LID GASKET	EPDM
NOT SHOWN	1	FF.PR.007	RESTRAINER BASKET	316SS 9/64' PERF

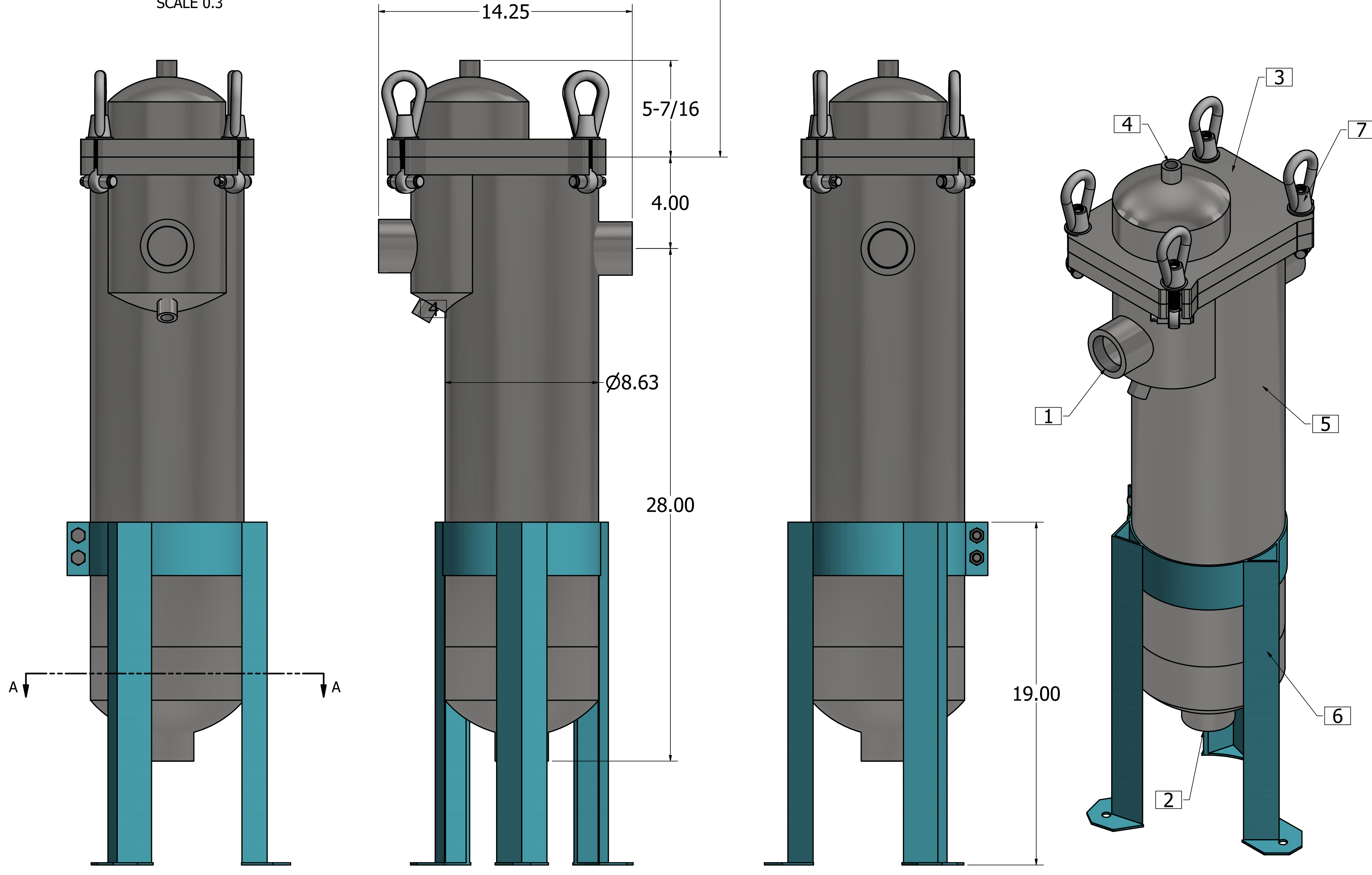

DRAWN J PERINO	2/18/2021	FLUID FILTRATION MFG CORP	
CHECKED		TITLE	
QA		FILTER ASSEMBLY	
MFG A SUBERO		FF.PR.2.0.NPTF.2.CS	
APPROVED A SUBERO		SIZE D	DWG NO FF.PR.2.0.NPTF.2.CS
		SCALE 0.3	REV
		SHEET 1 OF 1	

8 | 7 | 6 | 5 | 4 | 3 | 2 | 1