

8 | 7 | 6 | 5 | 4 | 3 | 2 | 1

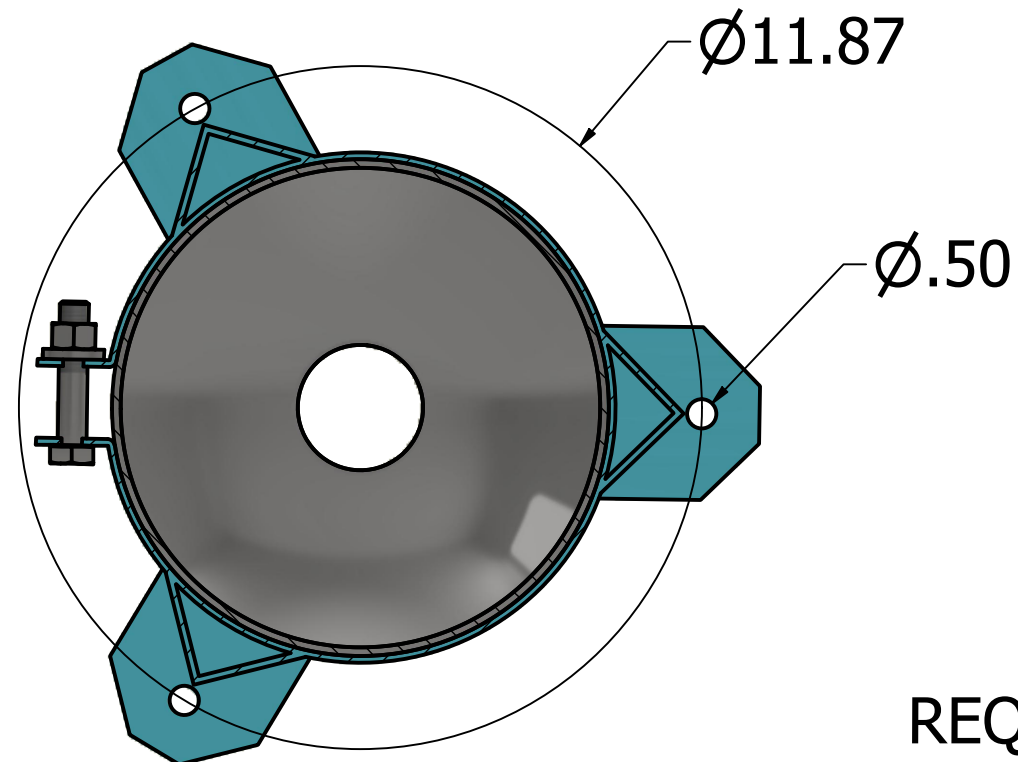

ALL DIMENSIONS ARE INCHES

CONSTRUCTION AS PER ASME SECTION VIII
 MAX WORKING PRESSURE: 150 PSI
 HYDROTEST PRESSURE 205 PSI
 MAX TEMP: 250°F
 MIN TEMP: -20°F

CERTIFIED DRAWING

CUSTOMER:

CUSTOMER PURCHASE ORDER:

STAND OFF HEIGHT
 REQUIRED FOR BASKET REMOVAL

17.00

17-1/16

Ø8.63

5-7/16

4.00

11.50

19.00

TABLE				
ITEM	QTY	PART NUMBER	DESCRIPTION	MATERIAL
1	2	NPTF-2.0	Inlet/Outlet Flanges 2"-150# SORF	ASTM A-182 Gr F1
2	1	FF.PR.006	Drain Connection 2" NPTF CLASS 3000	ASTM A-182
3	2	FF.PR.001	Top Cover; Includes upper flange/cap with integral handle	ASTM A-240
4	2	FF.PR.004	Vent connection and Inlet Drain Connection	ASTM A-182
5	1	FF.PR.002.2	Central Body 8-5/8" OD	ASTM A-312
6	1	FF.PR.003	Fabricated 1-1/12 Angle with band and locking bolt	ASTM A-240
7	4	SA-194-1 SA-193-B7	Eyebolt/Eyenuit Assembly Clevis Pin SS Clotter Pin	ASTM A-193-B7/ A-194-1 Cadmium Coated
NOT SHOWN	1	FF.PR.005	Lid Gasket	EPDM
NOT SHOWN	1	FF.PR.007	RESTRAINER BASKET	316SS 9/64' PERF

DRAWN J PERINO	2/8/2021	FLUID FILTRATION MFG CORP		
CHECKED A SUBERO	02/08/2021	TITLE		
QA		FILTER ASSEMBLY		
MFG A SUBERO	02/18/2021	FF.PR.2.0.150.1.316SS		
APPROVED AL BORZI		SIZE D	DWG NO FF.PR.2.0.150.1.SS	REV 1
		SCALE 0.3	SHEET 1 OF 1	

8 | 7 | 6 | 5 | 4 | 3 | 2 | 1